

Insulated Shaft Potentiometer 9mm Size Insulated Shaft Snap-in Type

RK09K/RK09D Series

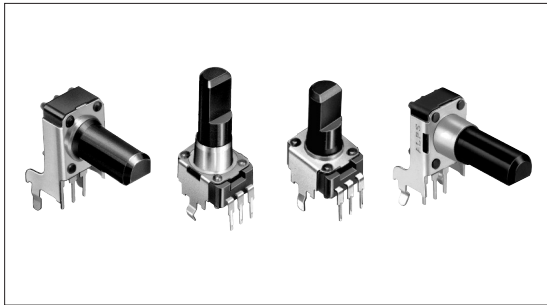

Compact type potentiometer with 9.8mm width is ideal for designing high density sets.



Typical Specifications

Items		Specifications
Total resistance tolerance	Single-unit	±20%
	Dual-unit	±30%
Maximum operating voltage	Single-unit	50V AC 20V DC
	Dual-unit	50V AC for AC only
Total rotational angle	Single-unit	RK09K: 280±5° RK09D: 300±5°
	Dual-unit	280±5°
Rotational torque		1 to 8mN·m
Operating life	Single-unit	5,000cycles
	Dual-unit	10,000cycles
Operating temperature range		-10°C to +70°C

Rotary Potentiometers
Slide Potentiometers

Metal Shaft
Insulated Shaft
Knob Operating
Ring Type Devices

Product Line

Number of resistor elements	Mounting direction	Total rotation angle	Collar (Sleeve type)	Shaft type	Length of the shaft (mm)	Center detent	Total resistance (kΩ)	Resistance taper	Minimum order unit (pcs.)	Products No.	Drawing No.
Single-unit (20V DC)	Vertical type	280±5°	Without	Flat	15	With	10	1B	2,000	RK09K113004U	2
							5			RK09K1130AU2	
							10			RK09K1130A6S	
						Without	20	RK09K1130AJ3			
							50	RK09K1130ACM			
							10	RK09K1130ACL			
				Knob	20	With	5	1B		RK09K1130AAU	
							10			RK09K1130AH1	
							15			RK09K1130BM4	
						Driver	30			RK09K1130A8G	
							15			RK09K1130A5R	
							20			RK09K1130081	
	Horizontal type H=6.5mm	20	Without	Flat	15	Without	10	15A	RK09K1130A70		
							20		RK09K1130AP5		
							5		RK09K1130AV7		
				Knob	20	With	10	1B	10	RK09K1110A2S	
									5	RK09K1110AK4	
									10	RK09K1110AH8	
	Horizontal type H=10mm	Vertical type	300±5°	With	Flat	20	Without	50	15A	RK09K1110B1V	5
								10		RK09K1110A0J	
								5		RK09K1110E9	
							With	10		RK09K1110B1R	
								50		RK09D1130C1B	
								10		RK09D1130C2P	
Horizontal type H=10mm		Vertical type	300±5°	With	Flat	25	Without	10	1B	RK09D1130A1L	4
								5		RK09D1130A1N	
								10		RK09D1130C3W	
							With	10		RK09D1130C3C	
								50		RK09D113000F	
								10		RK09D1110C0R	

Note

Products other than those listed in above products are also available. Please contact us for details.

Refer to P.388 for product varieties.
Refer to P.388, 389, 470 for resistance taper.

Rotary Potentiometers
 Slide Potentiometers

Product Line

Number of resistor elements	Mounting direction	Total rotation angle	Collar (Sleeve type)	Shaft type	Length of the shaft (mm)	Center detent	Total resistance (kΩ)	Resistance taper	Minimum order unit (pcs.)	Products No.	Drawing No.
Dual-unit (50V AC)	Vertical type	280±5°	Without	Flat	15	Without	10	15A	2,000	RK09K12C0A19	10
					20		50			RK09K12C0A2S	
					30		10			RK09K12C0A4D	
					25					RK09K12C0A8P	
	30		With		10	RK09K12C0A8K					
	15					RK09K12A0A2K					
	Horizontal type H=6.5mm				Without	50	RK09K12A0A6R				
							20			RK09K12A0B0W	

Metal Shaft
 Insulated Shaft
 Knob Operating
 Ring Type Devices

For the mixing console market

Number of resistor elements	Mounting direction	Total rotation angle	Collar (Sleeve type)	Shaft type	Length of the shaft (mm)	Center detent	Total resistance (kΩ)	Resistance taper	Minimum order unit (pcs.)	Products No.	Drawing No.
Single-unit (20V DC)	Vertical type	300±5°	With	Flat	30	With	10	1B	1,000	RK09D117000B	4
						Without		15A		RK09D117000C	

Note

Products other than those listed in above products are also available. Please contact us for details.

Packing specifications



Bulk

Number of packages (pcs.)		Export package measurements (mm)
1 case /Japan	1 case/export packing	
1,000	2,000	368 × 530 × 180

Dimensions

Single-shaft, single-unit

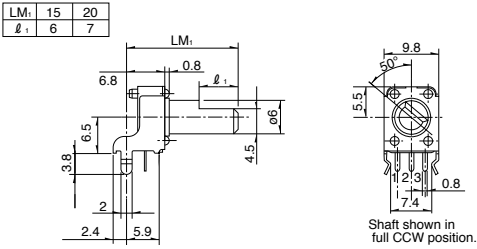
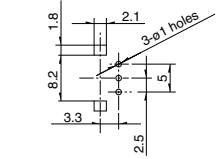
Unit:mm

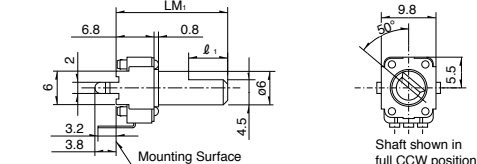
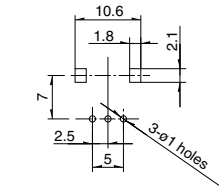
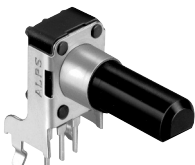
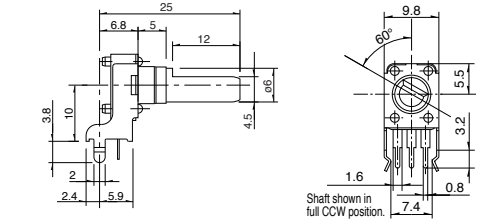
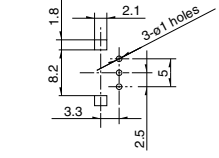



No.	Photo	Style	PC board mounting hole dimensions (Viewed from mounting side)
1		 <p>Shaft shown in full CCW position.</p>	
2		 <p>Mounting Surface Shaft shown in full CCW position.</p>	
3		 <p>Shaft shown in full CCW position.</p>	

Refer to P.388 for product varieties.
 Refer to P.388, 389, 470 for resistance taper.

Dimensions

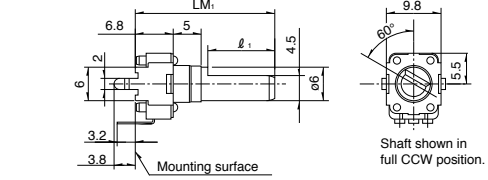
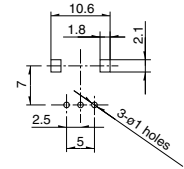
Single-shaft, single-unit

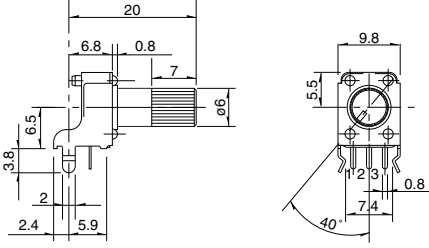
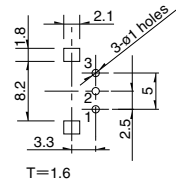
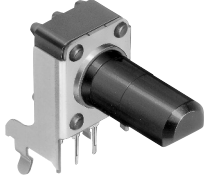
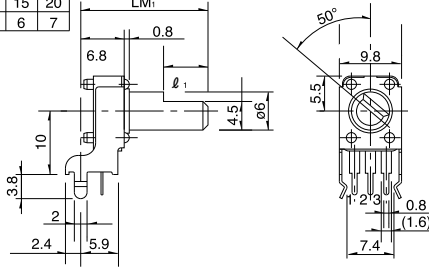
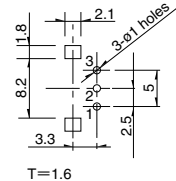
Unit:mm

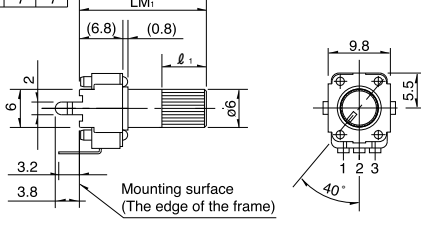
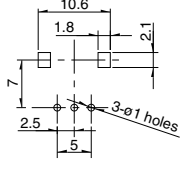
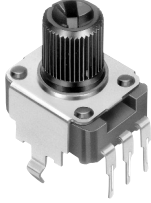
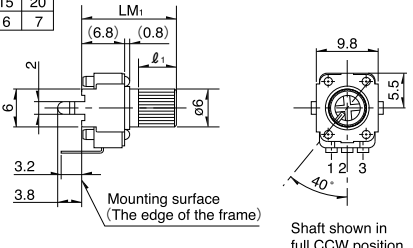
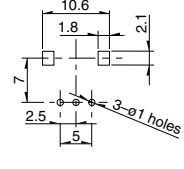
No.	Photo	Style	PC board mounting hole dimensions (Viewed from mounting side)								
4	Vertical type with collar RK09D113 	<table border="1"> <tr> <td>LM₁</td> <td>20</td> <td>25</td> <td>30</td> </tr> <tr> <td>ℓ₁</td> <td>7</td> <td>12</td> <td>12</td> </tr> </table>  <p>Shaft shown in full CCW position.</p>	LM ₁	20	25	30	ℓ ₁	7	12	12	
LM ₁	20	25	30								
ℓ ₁	7	12	12								
5	Horizontal type RK09K111 		 <p>T=1.6</p>								
6	Horizontal type RK09K111 	<table border="1"> <tr> <td>LM₁</td> <td>15</td> <td>20</td> </tr> <tr> <td>ℓ₁</td> <td>6</td> <td>7</td> </tr> </table> 	LM ₁	15	20	ℓ ₁	6	7	 <p>T=1.6</p>		
LM ₁	15	20									
ℓ ₁	6	7									
7	Vertical type RK09K113 	<table border="1"> <tr> <td>LM₁</td> <td>15</td> <td>20</td> <td>30</td> </tr> <tr> <td>ℓ₁</td> <td>6</td> <td>7</td> <td>7</td> </tr> </table>  <p>Mounting surface (The edge of the frame)</p>	LM ₁	15	20	30	ℓ ₁	6	7	7	
LM ₁	15	20	30								
ℓ ₁	6	7	7								
8	Vertical type RK09K113 	<table border="1"> <tr> <td>LM₁</td> <td>15</td> <td>20</td> </tr> <tr> <td>ℓ₁</td> <td>6</td> <td>7</td> </tr> </table>  <p>Mounting surface (The edge of the frame)</p> <p>Shaft shown in full CCW position.</p>	LM ₁	15	20	ℓ ₁	6	7			
LM ₁	15	20									
ℓ ₁	6	7									

Terminal Layout/Circuit Diagram

Single-unit

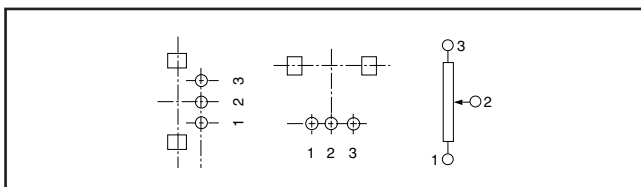

Dimensions

Single-shaft, dual-unit

Unit:mm

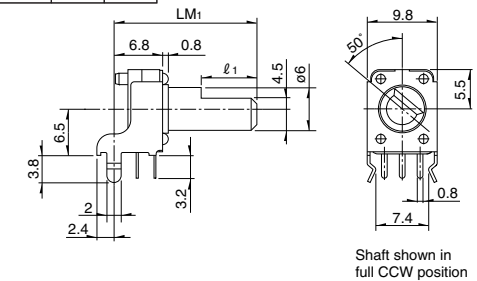
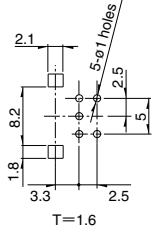
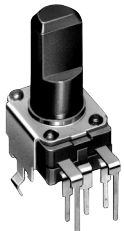
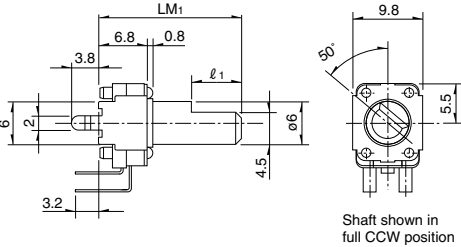
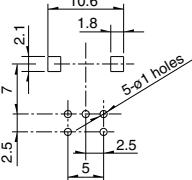
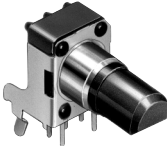
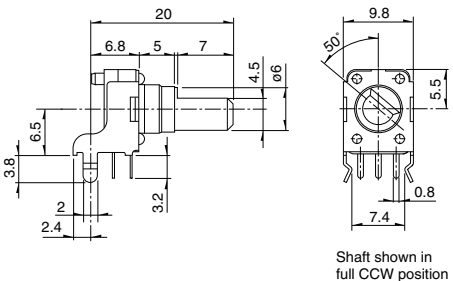
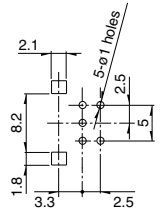
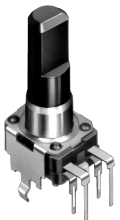
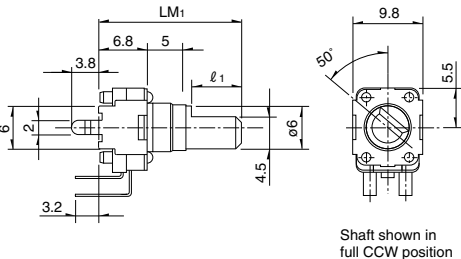
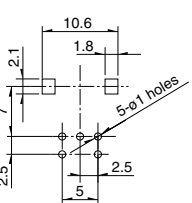
No.	Photo	Style	PC board mounting hole dimensions (Viewed from mounting side)								
9		<table border="1"> <tr> <td>LM₁</td> <td>15</td> <td>20</td> </tr> <tr> <td>ℓ₁</td> <td>6</td> <td>7</td> </tr> </table>  <p>Shaft shown in full CCW position</p>	LM ₁	15	20	ℓ ₁	6	7			
LM ₁	15	20									
ℓ ₁	6	7									
10		<table border="1"> <tr> <td>LM₁</td> <td>15</td> <td>20</td> <td>30</td> </tr> <tr> <td>ℓ₁</td> <td>6</td> <td>7</td> <td>12</td> </tr> </table>  <p>Shaft shown in full CCW position</p>	LM ₁	15	20	30	ℓ ₁	6	7	12	
LM ₁	15	20	30								
ℓ ₁	6	7	12								
11		 <p>Shaft shown in full CCW position</p>									
12		<table border="1"> <tr> <td>LM₁</td> <td>25</td> <td>30</td> </tr> <tr> <td>ℓ₁</td> <td>12</td> <td>12</td> </tr> </table>  <p>Shaft shown in full CCW position</p>	LM ₁	25	30	ℓ ₁	12	12			
LM ₁	25	30									
ℓ ₁	12	12									

Terminal Layout/Circuit Diagram

Dual-unit

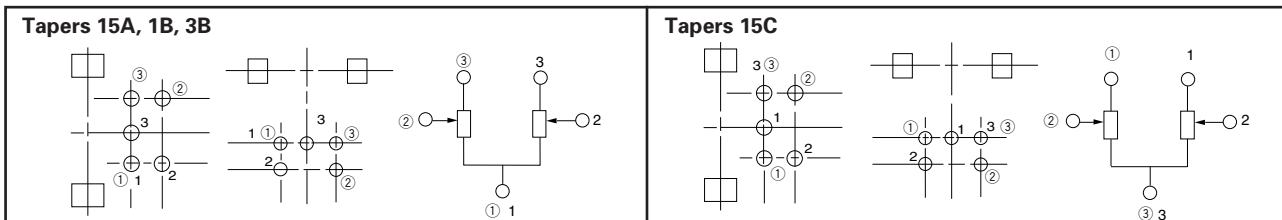

Product Varieties

In addition to the recommended products, the following specifications can also be accommodated.

Total Resistance Variety

Total resistance (kΩ)	5	10	20	50	100	200
-----------------------	---	----	----	----	-----	-----

Resistance Taper

Resistance taper	15A	1B	3B	15C
------------------	-----	----	----	-----

Shaft Variety

Unit:mm

Number of resistor elements	Style	Shaft type		Shaft color										
		Knob variety	Detail dimensions											
Single-unit		Knob type (φ6)	<table border="1"> <tr> <td>LM₁</td> <td>15</td> <td>20</td> <td>25</td> <td>30</td> </tr> <tr> <td>ℓ₁</td> <td>6</td> <td>7</td> <td>7</td> <td>7</td> </tr> </table>	LM ₁	15	20	25	30	ℓ ₁	6	7	7	7	Black
		LM ₁	15	20	25	30								
		ℓ ₁	6	7	7	7								
		Screw-driver adjustment type	<table border="1"> <tr> <td>LM₁</td> <td>9.5</td> <td>15</td> <td>20</td> <td></td> </tr> <tr> <td>ℓ₁</td> <td>—</td> <td>6</td> <td>7</td> <td></td> </tr> </table>	LM ₁	9.5	15	20		ℓ ₁	—	6	7		
		LM ₁	9.5	15	20									
		ℓ ₁	—	6	7									
Flat type	<table border="1"> <tr> <td>LM₁</td> <td>15</td> <td>20</td> <td>25</td> <td>30</td> </tr> <tr> <td>ℓ₁</td> <td>6</td> <td>7</td> <td>12</td> <td>12</td> </tr> </table>	LM ₁	15	20	25	30	ℓ ₁	6	7	12	12			
LM ₁	15	20	25	30										
ℓ ₁	6	7	12	12										
Flat type	<table border="1"> <tr> <td>LM₁</td> <td>15</td> <td>20</td> <td>25</td> <td>30</td> </tr> <tr> <td>ℓ₁</td> <td>6</td> <td>7</td> <td>12</td> <td>12</td> </tr> </table>	LM ₁	15	20	25	30	ℓ ₁	6	7	12	12	Gray (15,20,25) Black (30)		
LM ₁	15	20	25	30										
ℓ ₁	6	7	12	12										
With collar	<table border="1"> <tr> <td>LM₁</td> <td>20</td> <td>25</td> <td>30</td> </tr> <tr> <td>ℓ₁</td> <td>7</td> <td>12</td> <td>12</td> </tr> </table>	LM ₁	20	25	30	ℓ ₁	7	12	12	Black				
LM ₁	20	25	30											
ℓ ₁	7	12	12											
Flat type	<table border="1"> <tr> <td>LM₁</td> <td>20</td> <td>25</td> <td>30</td> </tr> <tr> <td>ℓ₁</td> <td>7</td> <td>12</td> <td>12</td> </tr> </table>	LM ₁	20	25	30	ℓ ₁	7	12	12	Gray (20,25) Black (30)				
LM ₁	20	25	30											
ℓ ₁	7	12	12											
Dual-unit		Flat type	<table border="1"> <tr> <td>LM₁</td> <td>15</td> <td>20</td> <td>25</td> <td>30</td> </tr> <tr> <td>ℓ₁</td> <td>6</td> <td>7</td> <td>12</td> <td>12</td> </tr> </table>	LM ₁	15	20	25	30	ℓ ₁	6	7	12	12	Black
		LM ₁	15	20	25	30								
ℓ ₁	6	7	12	12										
Flat type	<table border="1"> <tr> <td>LM₁</td> <td>20</td> <td>25</td> <td>30</td> </tr> <tr> <td>ℓ₁</td> <td>7</td> <td>12</td> <td>12</td> </tr> </table>	LM ₁	20	25	30	ℓ ₁	7	12	12					
LM ₁	20	25	30											
ℓ ₁	7	12	12											

Notes

1. marked are specifications recommended by ALPS.
2. RK09D117 is only for flat type of 20mm, 25mm, 30mm

Refer to P.389, 470 for resistance taper.

Orders Other Than Recommended Products

When ordering product varieties that are not listed in the Product Line, please specify by referring to the below example.

Sample Part Number



Model type

Code	Model type
K111	280° single-unit horizontal type H=6.5
K113	280° single-unit vertical type
D111	300° single-unit horizontal type H=10
D113	300° single-unit vertical type
K12A	280° dual-unit horizontal type H=6.5
K12C	280° dual-unit vertical type

* All RK09D types are single-ganged.
 * For other horizontal type mount height requirements, please indicate separately.

Shaft type

Code	Shaft type	Code	Shaft type
F	Flat	X	Driver
K	Knob		

* All RK09D types are only available in flat format.

Length of the shaft (LM₁) (mm)

Code	Length of the shaft	Code	Length of the shaft
15	15	25	25
20	20	30	30

* 20, 25 and 30 are the only available RK09D types.
 * 9.5, 15 and 20 are the only available models in the driver shape.

Detent

Code	Center detent
C0	Without
C1	With

Resistance taper

Code	Resistance taper	Code	Resistance taper
A	15A	C	15C
B	1B	V	3B

B: For tone & general
 V: For vol.

* 1B is a recommended specification for single-unit.
 * 3B is a recommended specification for dual-unit.

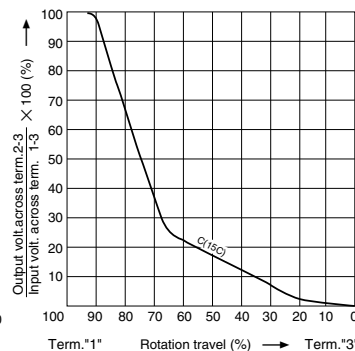
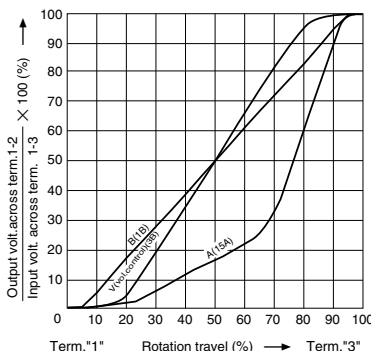

Total resistance

Code	Total resistance (kΩ)	Code	Total resistance (kΩ)
502	5	503	50
103	10	104	100
203	20	204	200

Notes

1. RK09D comes with a collar.
2. The recommended specification for RK09K does not include a collar. For collar requirements please indicate separately.
3. [Shaded] marked are specifications recommended by ALPS.

Rotary Potentiometers
Slide Potentiometers

Metal Shaft

Insulated Shaft

Knob Operating

Ring Type Devices

List of Varieties

Items	Type	9mm Size Insulated Shaft Snap-in		11mm Size Insulated Shaft Snap-in	12mm Size Insulated Shaft Snap-in	14mm Size Insulated Shaft Snap-in	9mm Size Insulated shaft Long-life	12mm Size Insulated shaft Snap-in	
	Model	RK09K11□ RK09D11□	RK09K12□	RK11K11□	RK12L12□	RK14K12□	RK09Y11L	RK12L115	
		Single-unit	Dual-unit	Single-unit	Dual-unit		Single-unit		
Photo									
Bushing	Without		With/With out	Without	With/With out	Without	With		
Operating temperature range	-10°C to +70°C							-40°C to +85°C	
Automotive use								○	
Electrical performance	Total resistance tolerance	±20%	±30%	±20%			±30%	±20%	
	Maximum operating voltage	50V AC 20V DC	50V AC For AC only	50V AC 20V DC	50V AC For AC only		50V AC 5V DC	50V AC 20V DC	
	Insulation resistance	100MΩ min. 250V DC		100MΩ min. 500V DC	100MΩ min. 250V DC				
	Voltage proof	250V AC for 1minute		500V AC for 1minute	300V AC for 1minute		250V AC for 1minute	300V AC for 1minute	
	Gang error	—	-40dB to 0dB 3dB max.	—	Volume control -40dB to 0dB 3dB max. For tone control within 2dB at center		—		
Mechanical performance	Strength of the actuator	Stopper strength	0.3N·m		Without bushing 0.5N·m With bushing 0.6N·m	0.5N·m	0.6N·m	—	0.5N·m
		Push-pull strength	50N max.		80N max.		30N max.	80N max.	
	Vibration		10 to 55 to 10Hz/min., the amplitude is 1.5mm for all the frequencies, in the 3 direction of X, Y and Z and for 2 hours respectively						
	Resistance to soldering heat	Manual soldering	350°C max. 3s max.						
Dip Soldering		—		260°C max. 5s max.	—				
Environmental performance	Cold	-30±2°C for 96h					-30±2°C for 240h	-40±3°C for 96h	
	Dry heat	70±2°C for 96h			70±2°C for 240h	70±2°C for 96h	70±2°C for 240h	85±3°C for 96h	
	Damp heat	40±2°C, 90 to 95% RH for 96h					40±2°C, 90 to 95% RH for 240h	40±2°C, 90 to 95% RH for 96h	
Page	384		390	394	397	401	402		

● Insulated Shaft Potentiometers Cautions404, 405

Note

○marks in "Available for automotive use" indicate that some of the series products can work at the operating temperature range from -40°C to +85°C.

Rotary Potentiometers
Slide Potentiometers

Metal Shaft
Insulated Shaft
Knob Operating
Ring Type Devices